

# Model: D3DA-50 X

## Data

---

Type: Semi-hermetic piston compressors

Producer: Copeland

Series: DISCUS

## Model: D3DA-50 X

### Technical data

Cylinder count:	3
Displacement [m <sup>3</sup> /h]:	32,2
Weight [kg]:	157
Oil charge [dm <sup>3</sup> ]:	3,4
Max. operating current [A]:	12
Locked rotor current [A]:	55
Power supply [V/~/Hz]:	380-420V/3/50Hz

### Connections

	<u>milimeters</u>	<u>inches</u>
Suction line:		1 3/8"
Discharge line:		7/8"

# Model: D3DA-50 X

## Capacity

---

R134a

### Cooling capacity [kW]

$t_c \setminus t_e$	-20	-15	-10	-5	0	5	10
30	6.60	8.77	11.36	14.42	18.03	22.24	27.12
35	5.98	8.07	10.54	13.48	16.93	20.96	25.63
40	5.38	7.37	9.74	12.53	15.81	19.65	24.11
45	4.80	6.70	8.93	11.58	14.69	18.33	22.57
50	4.24	6.03	8.14	10.63	13.56	17.00	21.01
55	3.71	5.38	7.35	9.67	12.41	15.64	19.41
60	3.20	4.75	6.57	8.72	11.26	14.27	17.80

### Power input [kW]

$t_c \setminus t_e$	-20	-15	-10	-5	0	5	10
30	2.82	3.09	3.32	3.49	3.58	3.59	3.49
35	2.91	3.24	3.53	3.77	3.94	4.03	4.03
40	2.99	3.37	3.72	4.02	4.27	4.45	4.53
45	3.06	3.48	3.89	4.26	4.57	4.83	5.00
50	3.11	3.58	4.03	4.46	4.85	5.18	5.43
55	3.14	3.65	4.16	4.64	5.09	5.49	5.82
60	3.15	3.70	4.25	4.79	5.30	5.77	6.18

# Model: D3DA-50 X

## Capacity

---

### Current [A]

$t_c \setminus t_e$	-20	-15	-10	-5	0	5	10
30	6.04	6.42	6.75	7.00	7.14	7.14	7.00
35	6.17	6.63	7.05	7.40	7.65	7.79	7.79
40	6.29	6.82	7.32	7.77	8.14	8.40	8.53
45	6.38	6.98	7.57	8.12	8.59	8.97	9.24
50	6.45	7.12	7.79	8.42	9.00	9.50	9.90
55	6.49	7.22	7.97	8.69	9.37	9.98	10.50
60	6.50	7.29	8.11	8.92	9.70	10.42	11.06

### Mass flow [kg/s]

$t_c \setminus t_e$	-20	-15	-10	-5	0	5	10
30	155.90	203.29	257.79	320.52	392.56	475.01	568.98
35	148.34	196.10	250.87	313.75	385.83	468.23	562.03
40	140.80	188.75	243.62	306.49	378.47	460.64	554.11
45	133.16	181.16	235.96	298.66	370.36	452.15	545.13
50	125.34	173.22	227.80	290.17	361.43	442.68	535.01
55	117.25	164.85	219.04	280.92	351.58	432.12	523.63
60	108.80	155.96	209.60	270.82	340.71	420.39	510.93

# Model: D3DA-50 X



Capacity

## C.O.P. [W/W]

$t_c \setminus t_e$	-20	-15	-10	-5	0	5	10
30	2.34	2.84	3.42	4.14	5.03	6.19	7.76
35	2.05	2.49	2.99	3.58	4.30	5.20	6.36
40	1.80	2.19	2.62	3.11	3.70	4.42	5.32
45	1.57	1.92	2.30	2.72	3.21	3.80	4.52
50	1.37	1.69	2.02	2.38	2.80	3.28	3.87
55	1.18	1.47	1.77	2.08	2.44	2.85	3.33
60	1.02	1.28	1.54	1.82	2.12	2.47	2.88

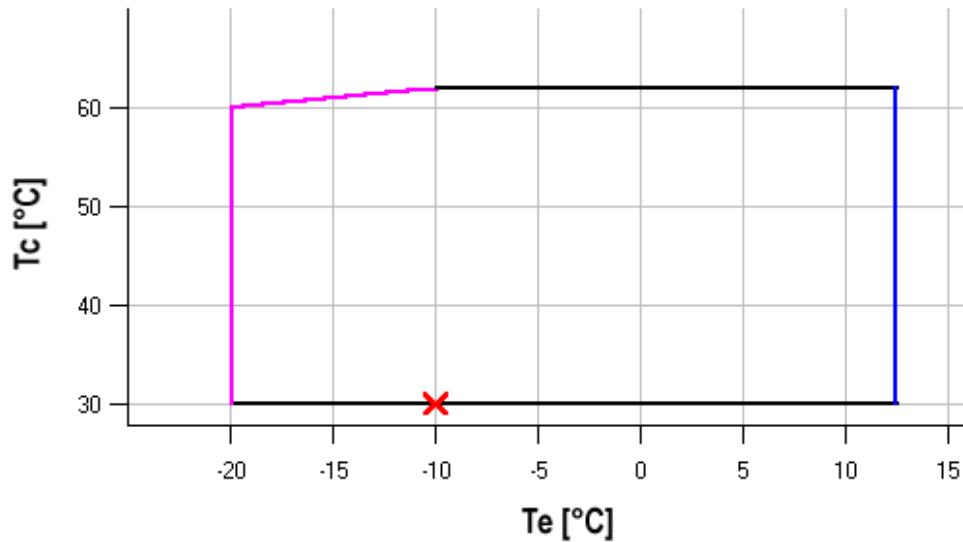
## Application range



 Maximum evaporating temperature  
 25°C suction gas return

Operating conditions: ISO; subcooling: 0 K, suction superheat: 10 K, return gas temperature: -  
 $t_c$  - Condensing temperature [°C]  
 $t_e$  - Evaporating temperature [°C]

# Model: D3DA-50 X

## Capacity

R404A/R507

### Cooling capacity [kW]

$t_c \setminus t_e$	-50	-45	-40	-35	-30	-25	-20
20	3.18	4.46	6.04	7.94	10.21	12.87	15.96
25	2.80	4.01	5.49	7.26	9.38	11.87	14.76
30	2.44	3.57	4.95	6.60	8.57	10.89	13.59
35	2.08	3.14	4.42	5.96	7.78	9.93	12.44
40	-	2.73	3.92	5.33	7.01	8.99	11.31
45	-	2.34	3.43	4.72	6.26	8.07	10.20
50	-	-	2.96	4.13	5.53	7.18	9.11
55	-	-	2.51	3.57	4.82	6.30	8.05

### Power input [kW]

$t_c \setminus t_e$	-50	-45	-40	-35	-30	-25	-20
20	2.27	2.71	3.13	3.52	3.88	4.21	4.50
25	2.24	2.72	3.19	3.63	4.05	4.45	4.81
30	2.19	2.71	3.22	3.72	4.20	4.66	5.09
35	2.12	2.68	3.24	3.79	4.32	4.84	5.34
40	-	2.63	3.24	3.83	4.43	5.01	5.58
45	-	2.57	3.22	3.87	4.52	5.16	5.80
50	-	-	3.18	3.88	4.59	5.30	6.00
55	-	-	3.14	3.89	4.65	5.42	6.20

# Model: D3DA-50 X

## Capacity

---

### Current [A]

$t_c \setminus t_e$	-50	-45	-40	-35	-30	-25	-20
20	5.48	6.02	6.56	7.09	7.60	8.06	8.46
25	5.40	5.98	6.60	7.21	7.82	8.40	8.93
30	5.31	5.95	6.63	7.33	8.03	8.72	9.37
35	5.22	5.91	6.65	7.43	8.22	9.02	9.79
40	-	5.86	6.66	7.51	8.39	9.29	10.18
45	-	5.78	6.64	7.56	8.53	9.53	10.53
50	-	-	6.59	7.58	8.63	9.72	10.84
55	-	-	6.50	7.56	8.69	9.88	11.10

### Mass flow [kg/s]

$t_c \setminus t_e$	-50	-45	-40	-35	-30	-25	-20
20	66.98	96.66	132.12	174.54	225.12	285.04	355.50
25	62.39	91.32	125.94	167.43	216.98	275.79	345.04
30	57.50	85.70	119.50	160.07	208.61	266.30	334.35
35	52.37	79.86	112.84	152.50	200.04	256.65	323.51
40	-	73.85	106.03	144.80	191.35	246.87	312.56
45	-	67.73	99.12	137.01	182.59	237.05	301.57
50	-	-	92.19	129.21	173.82	227.22	290.60
55	-	-	85.28	121.44	165.11	217.46	279.70

# Model: D3DA-50 X





## Capacity

### C.O.P. [W/W]

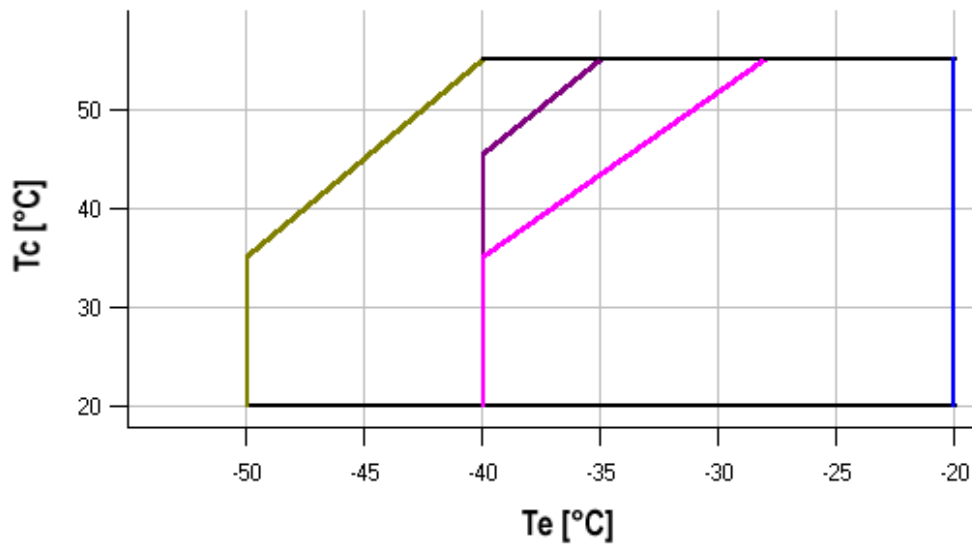
$t_c \setminus t_e$	-50	-45	-40	-35	-30	-25	-20
20	1.40	1.65	1.93	2.25	2.63	3.05	3.54
25	1.25	1.47	1.72	2.00	2.31	2.67	3.07
30	1.11	1.32	1.53	1.77	2.04	2.34	2.67
35	0.98	1.17	1.37	1.57	1.80	2.05	2.33
40	-	1.04	1.21	1.39	1.58	1.79	2.03
45	-	0.91	1.07	1.22	1.39	1.56	1.76
50	-	-	0.93	1.06	1.20	1.35	1.52
55	-	-	0.80	0.92	1.04	1.16	1.30

### Application range



-  Maximum evaporating temperature
-  25°C suction gas return
-  0°C suction gas return + additional cooling
-  0°C suction gas return

Operating conditions: ISO; subcooling: 0 K, suction superheat: - K, return gas temperature: 20

$t_c$  - Condensing temperature [°C]

$t_e$  - Evaporating temperature [°C]

# Model: D3DA-50 X

## Dimensions

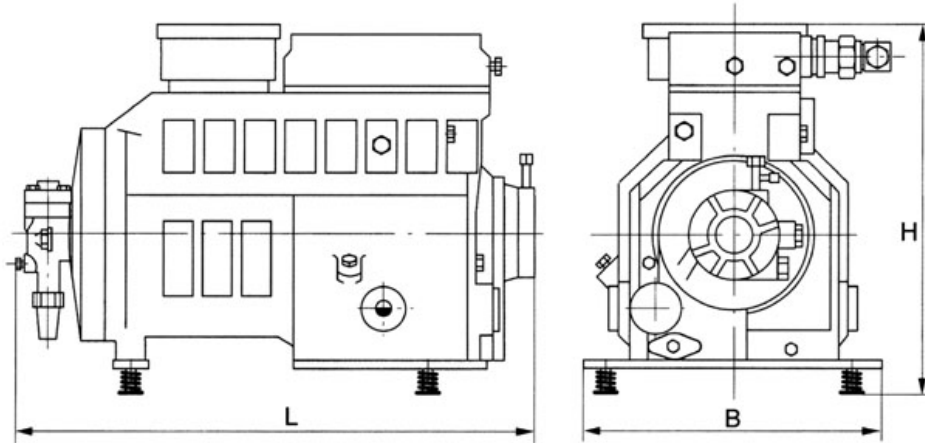

L	655 mm
B	370 mm
H	480 mm



# Model: D3DA-50 X

Image

---

